

USED ON	SCALE 1:1	TITLE Circular Vial , Ø50.8mm	DRAWING NUMBER 5563/1		
---------	--------------	----------------------------------	--------------------------	--	--

ISSUE	AMENDMENT	DATE
0	Opened for production	22/01/2004

Black Marking Ring, Ø15.6
Bubble, Ø14.0mm @ 20C

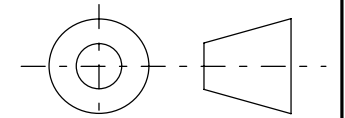
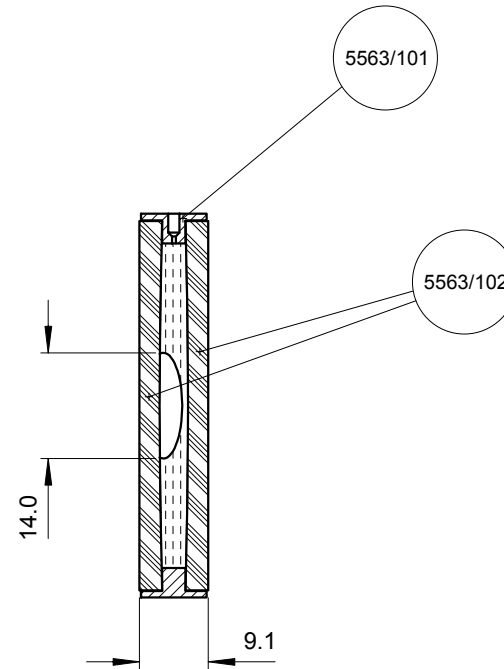
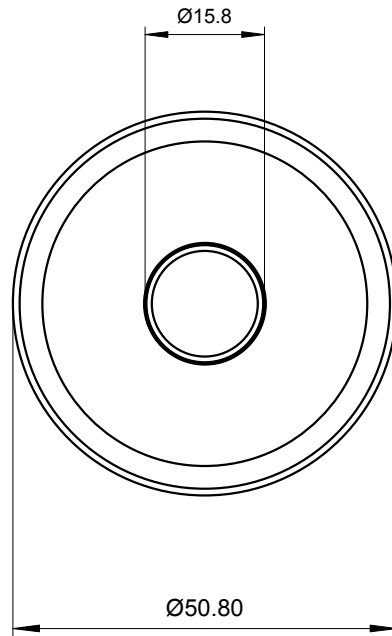

Third Angle Projection

FINISH	TOLERANCES UNLESS STATED OTHERWISE mm UNITS	XX. +/- 1.0 XX.X +/- 0.25 XX.XX +/- 0.1	MATERIAL	LEVEL DEVELOPMENTS Croydon, Surrey, CRO 2DN
			DRAWN BY JHL	