

USED ON	SCALE 3:1	TITLE Circular vial, 15mm, sensitivity 20'/2mm	DRAWING NUMBER 5564/1		
---------	---------------------	--	---------------------------------	--	--

ISSUE	AMENDMENT	DATE
-------	-----------	------

Black Marking Ring, Ø6.35

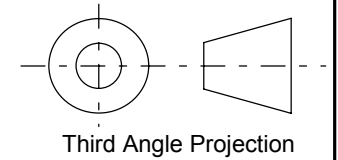
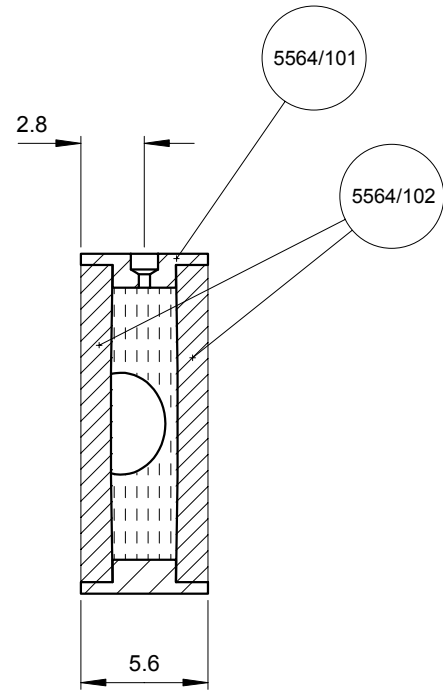
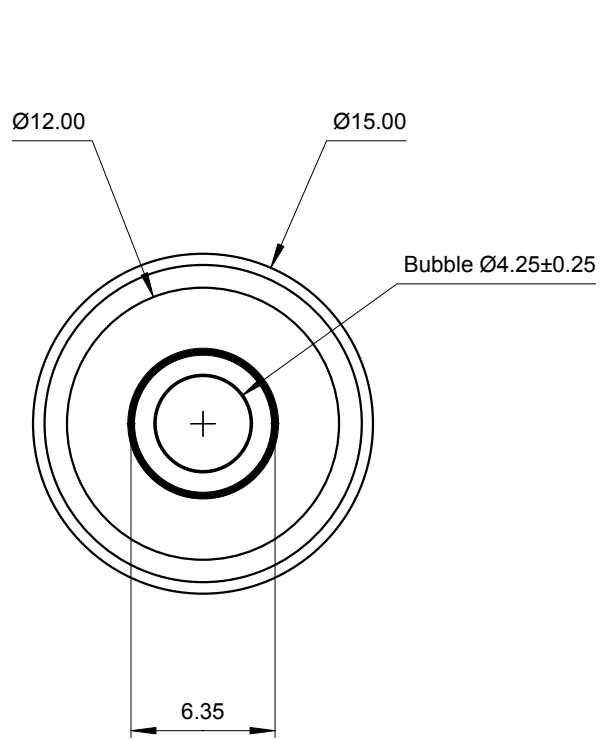

FINISH	TOLERANCES UNLESS STATED OTHERWISE mm UNITS	XX. +/- 1.0 XX.X +/- 0.25 XX.XX +/- 0.1	MATERIAL	LEVEL DEVELOPMENTS Croydon, Surrey, CRO 2DN	
			DRAWN BY J.H.L		