

USED ON	SCALE 3:1	TITLE Circular vial, 18mm dia., 10'2mm	DRAWING NUMBER 5571/1		
---------	---------------------	--	---------------------------------	--	--

ISSUE	AMENDMENT	DATE

Black Marking Ring, Ø7.00

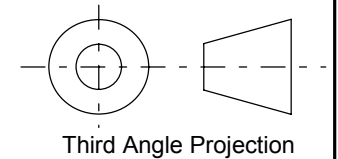
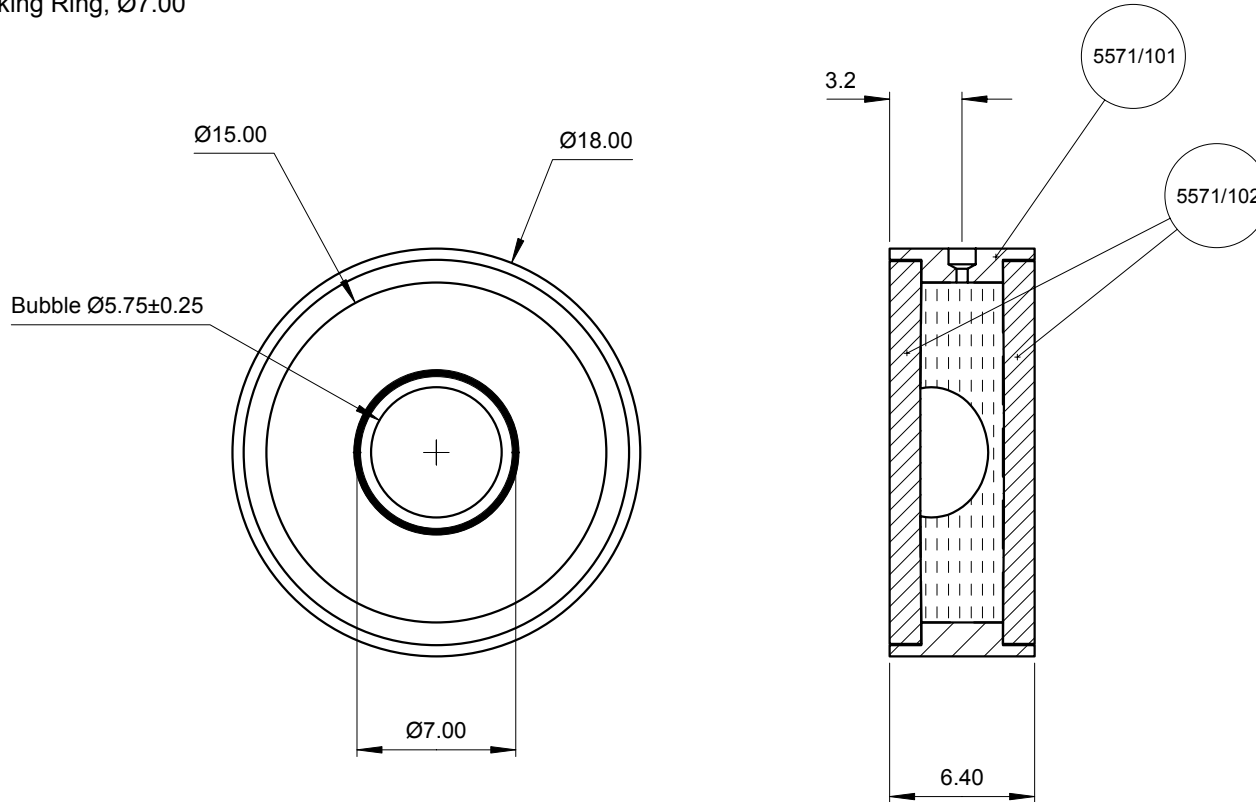

FINISH	TOLERANCES UNLESS STATED OTHERWISE mm UNITS	XX. +/- 1.0 XX.X +/- 0.25 XX.XX +/- 0.1	MATERIAL Aluminium BS4300/5 2011T3	LEVEL DEVELOPMENTS Croydon, Surrey, CRO 2DN	
			DRAWN BY Martin Jones		