

USED ON	SCALE 3:1	TITLE Circular vial, 15mm, sensitivity 7/2mm	DRAWING NUMBER 5580/1		
---------	--------------	---	--------------------------	--	--

ISSUE	AMENDMENT	DATE
-------	-----------	------

Note:  
Black Marking Ring : Ø5.50  
Sensitivity : 7/2mm

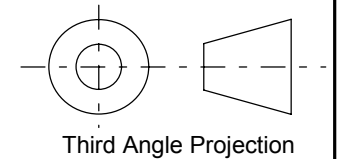
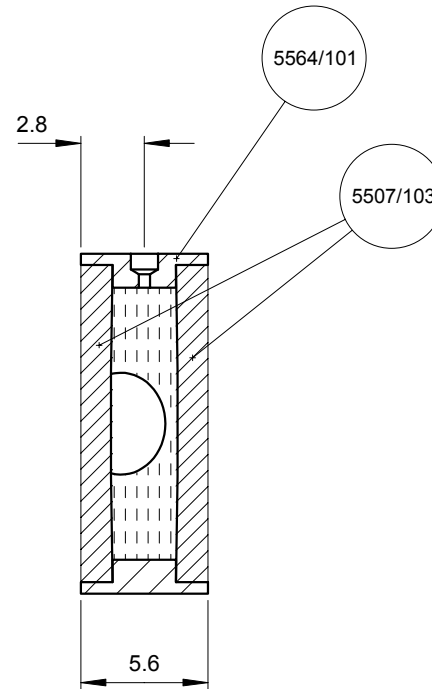
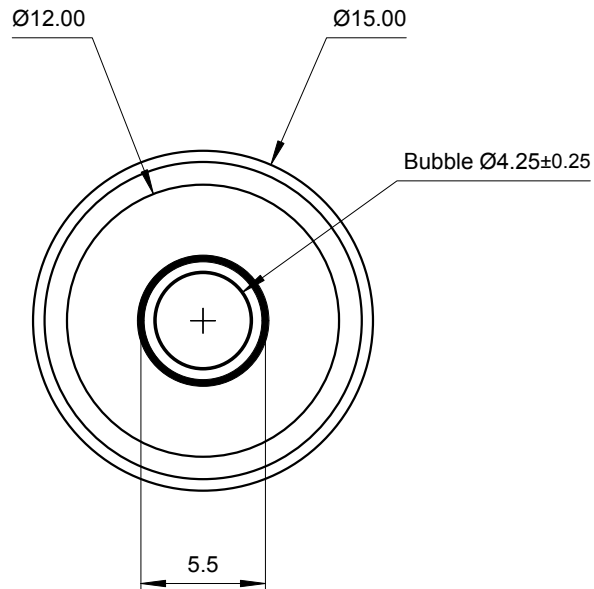

FINISH	TOLERANCES UNLESS STATED OTHERWISE mm UNITS	<b>XX.</b> +/- 1.0 <b>XX.X</b> +/- 0.25 <b>XX.XX</b> +/- 0.1	MATERIAL	<b>LEVEL DEVELOPMENTS</b> Croydon, Surrey, CRO 2DN	
			DRAWN BY J.H.L		