

USED ON	SCALE 3:1	TITLE Circular vial 15.5mm dia, sens 45'/0.1"	DRAWING NUMBER 5586/1		
---------	--------------	--	--------------------------	--	--

ISSUE	AMENDMENT	DATE

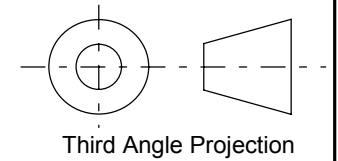
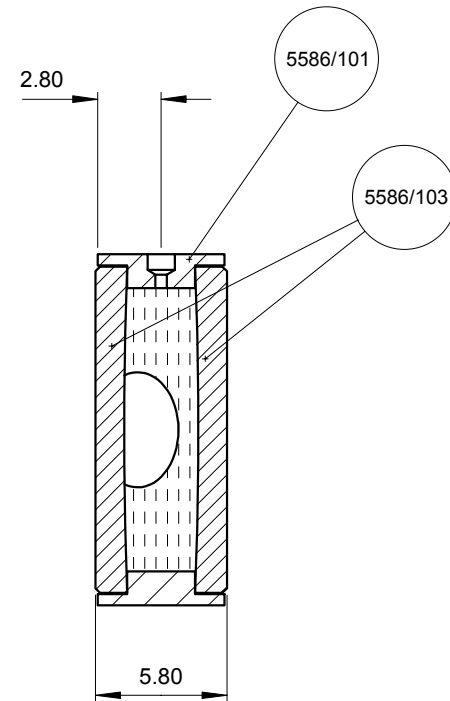
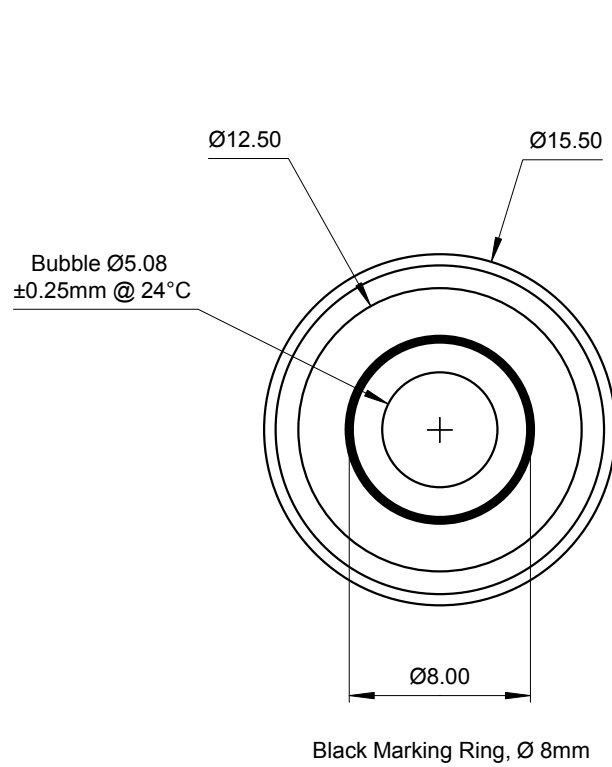

FINISH	TOLERANCES UNLESS STATED OTHERWISE mm UNITS	<b>XX.</b> $\pm 1.0$ <b>XX.X</b> $\pm 0.25$ <b>XX.XX</b> $\pm 0.1$	MATERIAL	<b>LEVEL DEVELOPMENTS</b> Croydon, Surrey, CRO 2DN	
			DRAWN BY Martin Jones		