

USED ON	SCALE 3:1	TITLE Circular vial 15.5mm dia, transparent, 20'0.1"	DRAWING NUMBER 5586/2		
---------	--------------	---	--------------------------	--	--

ISSUE	AMENDMENT	DATE

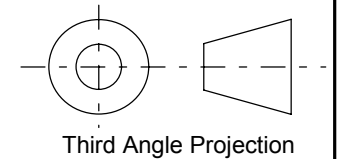
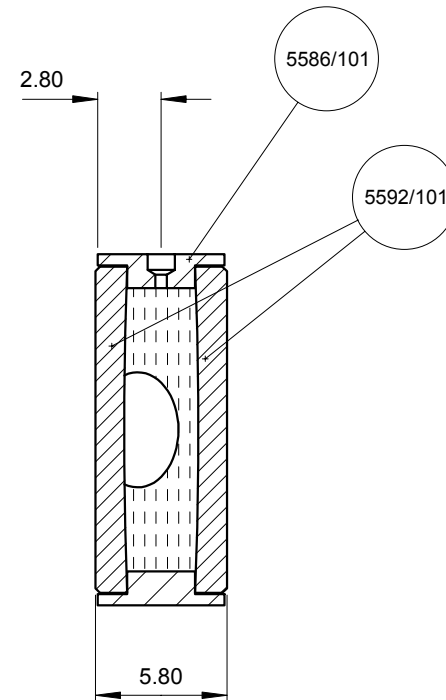
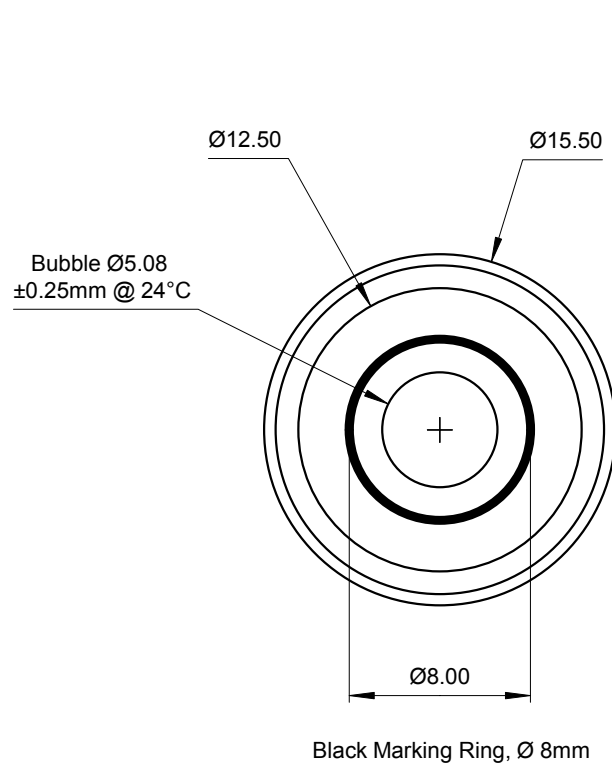

FINISH	TOLERANCES UNLESS STATED OTHERWISE mm UNITS	<b>XX.</b> +/- 1.0 <b>XX.X</b> +/- 0.25 <b>XX.XX</b> +/- 0.1	MATERIAL	<b>LEVEL DEVELOPMENTS</b> Croydon, Surrey, CRO 2DN
			DRAWN BY Martin Jones	