

USED ON	SCALE 3:1	TITLE Circular vial 15.5mm dia sens 45'/0.1"	DRAWING NUMBER 5590/1		
---------	---------------------	--	---------------------------------	--	--

ISSUE	AMENDMENT	DATE
1	Bubble diameter tolerance changed	26/08/2004

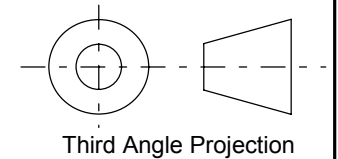
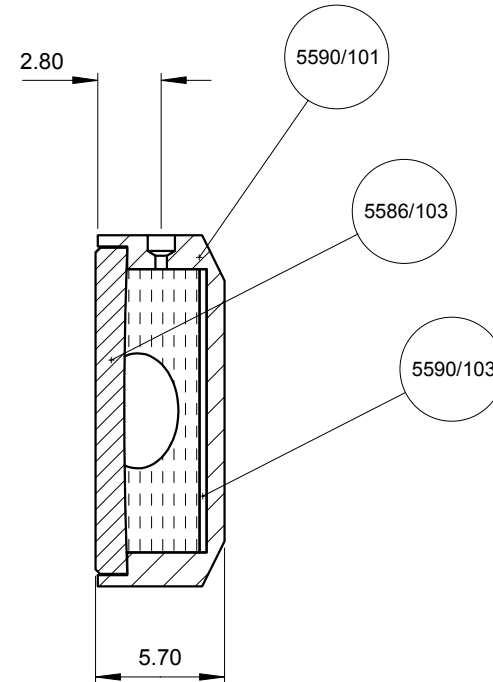
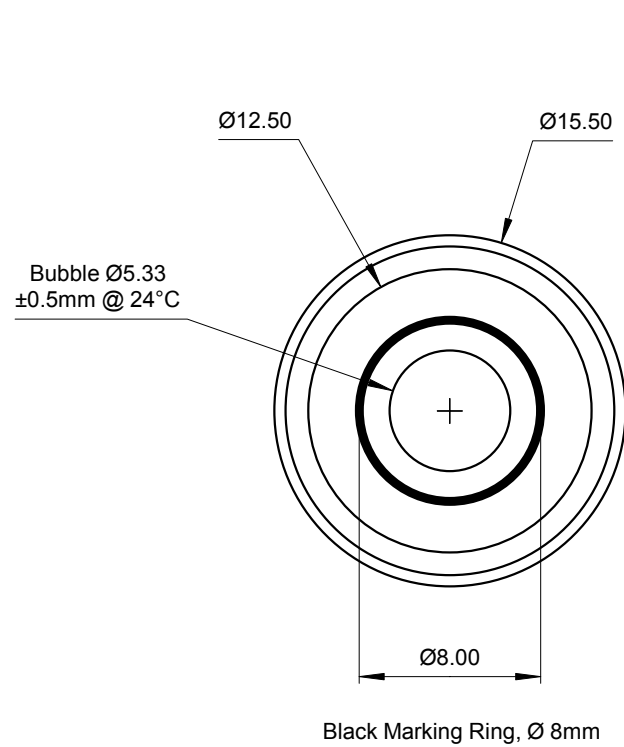

FINISH	TOLERANCES UNLESS STATED OTHERWISE mm UNITS	XX. +/- 1.0 XX.X +/- 0.25 XX.XX +/- 0.1	MATERIAL	LEVEL DEVELOPMENTS Croydon, Surrey, CRO 2DN	
			DRAWN BY Martin Jones		