

USED ON	SCALE 3:1	TITLE Circular vial, Ø15mm, sensitivity 7½mm	DRAWING NUMBER 5661/1	
---------	---------------------	--	---------------------------------	--

ISSUE	AMENDMENT	DATE
1	Internal Bore size reduced from Ø12 to Ø11mm	19/03/2008

Red Marking Ring, Ø6.00

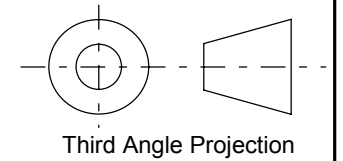
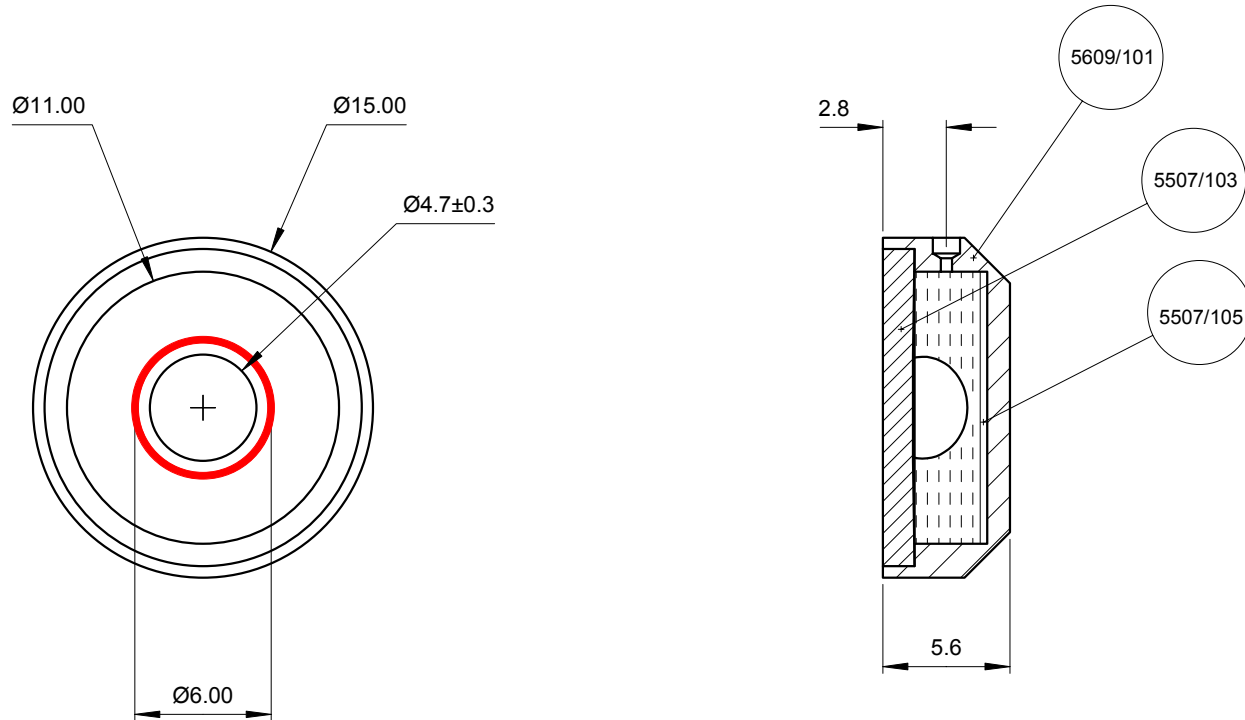

FINISH Black Anodised	TOLERANCES UNLESS STATED OTHERWISE mm UNITS	XX. +/- 1.0 XX.X +/- 0.25 XX.XX +/- 0.1	MATERIAL Aluminium housing, glass top disc	LEVEL DEVELOPMENTS Croydon, Surrey, CRO 2DN
			DRAWN BY J.H.L	