

USED ON	SCALE 1:1	TITLE Circular Vial Ø39.5, range 4°	DRAWING NUMBER 5671/1	
---------	--------------	--	--------------------------	--

ISSUE	AMENDMENT	DATE
0	Opened for production	12/07/2005

Black markings, printed on inside surface
Bubble diameter 9.0-9.5mm @ 20°C

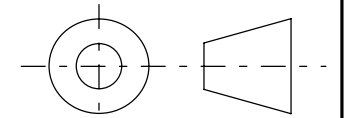
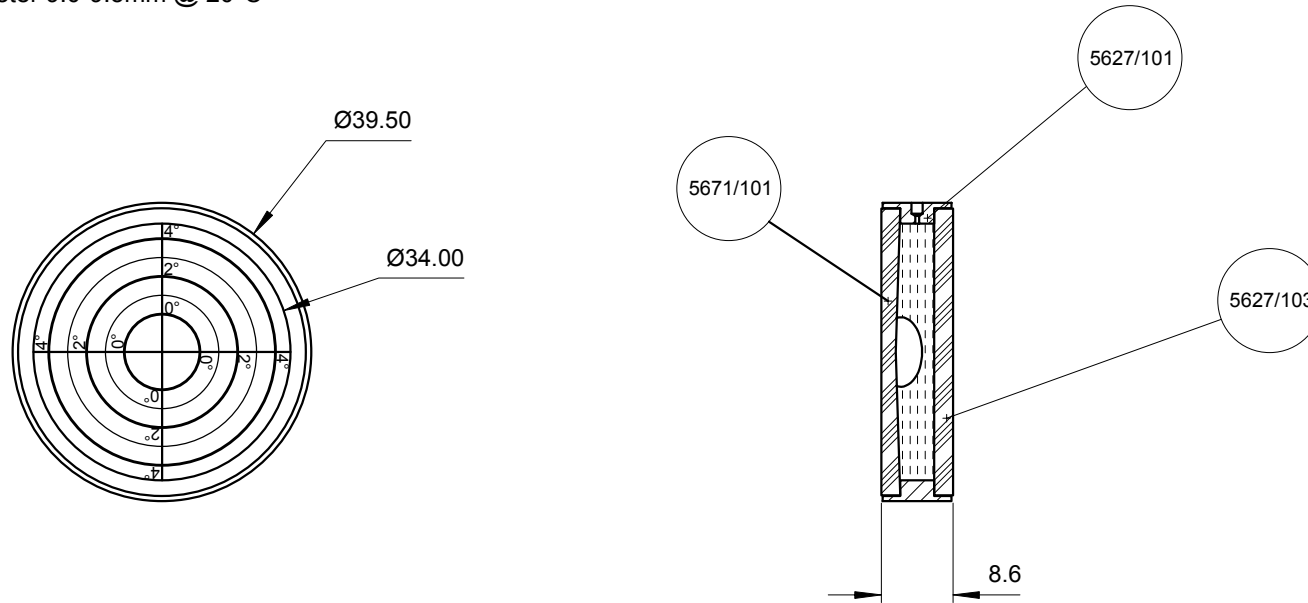

Third Angle Projection

FINISH Black Anodise	TOLERANCES UNLESS STATED OTHERWISE mm UNITS	XX. +/- 1.0 XX.X +/- 0.25 XX.XX +/- 0.1	MATERIAL Aluminium housing, glass top and bottom	LEVEL DEVELOPMENTS Croydon, Surrey, CRO 2DN
			DRAWN BY M. Jones	