

USED ON	SCALE 1:1	TITLE Circular Vial , Ø50.8mm, Sens 1°/2.5mm	DRAWING NUMBER 5673/1	
---------	--------------	---	--------------------------	--

ISSUE	AMENDMENT	DATE
0	Opened for production	

Black Marking Rings, see drawing 5673/101 for details  
 Printed on inside surface  
 Bubble size : Ø14.2 - 14.6mm @ 20°C

Bubble Ø14.4±0.2

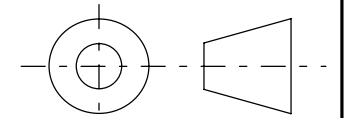
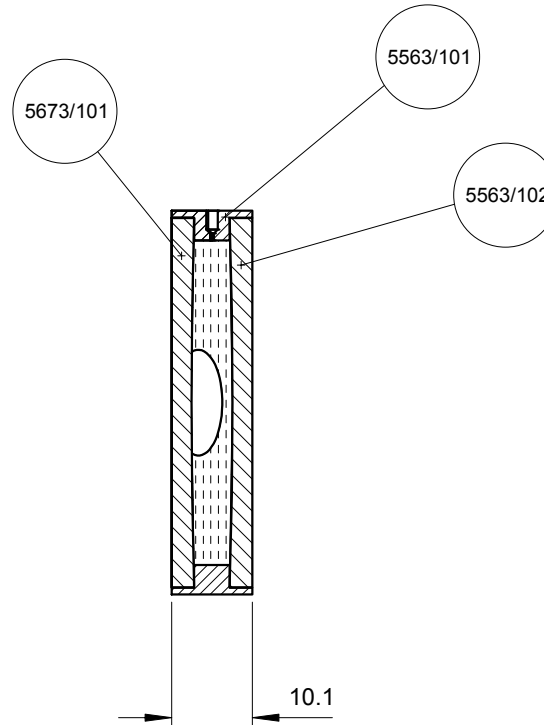
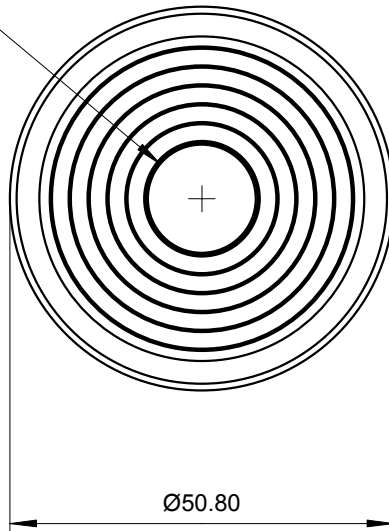

Third Angle Projection

FINISH	TOLERANCES UNLESS STATED OTHERWISE mm UNITS	<b>XX.</b> +/- 1.0 <b>XX.X</b> +/- 0.25 <b>XX.XX</b> +/- 0.1	MATERIAL	<b>LEVEL DEVELOPMENTS</b> Croydon, Surrey, CRO 2DN
			DRAWN BY JHL	