

USED ON	SCALE <b>2:1</b>	TITLE <b>Circular vial, Ø15 x 7mm</b>	DRAWING NUMBER <b>5732/1</b>
---------	---------------------	--	---------------------------------

ISSUE	AMENDMENT	DATE
0	Drawing opened for production	30/05/2007

Note:  
Sensitivity : 6.88°/2mm bubble movement (r=1000mm)  
Centre Ring : Ø6.00mm (Red)  
Bubble : Ø4.0 ±0.5 (@20°C)

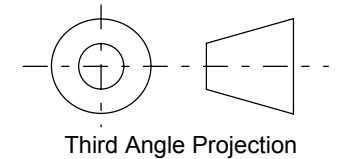
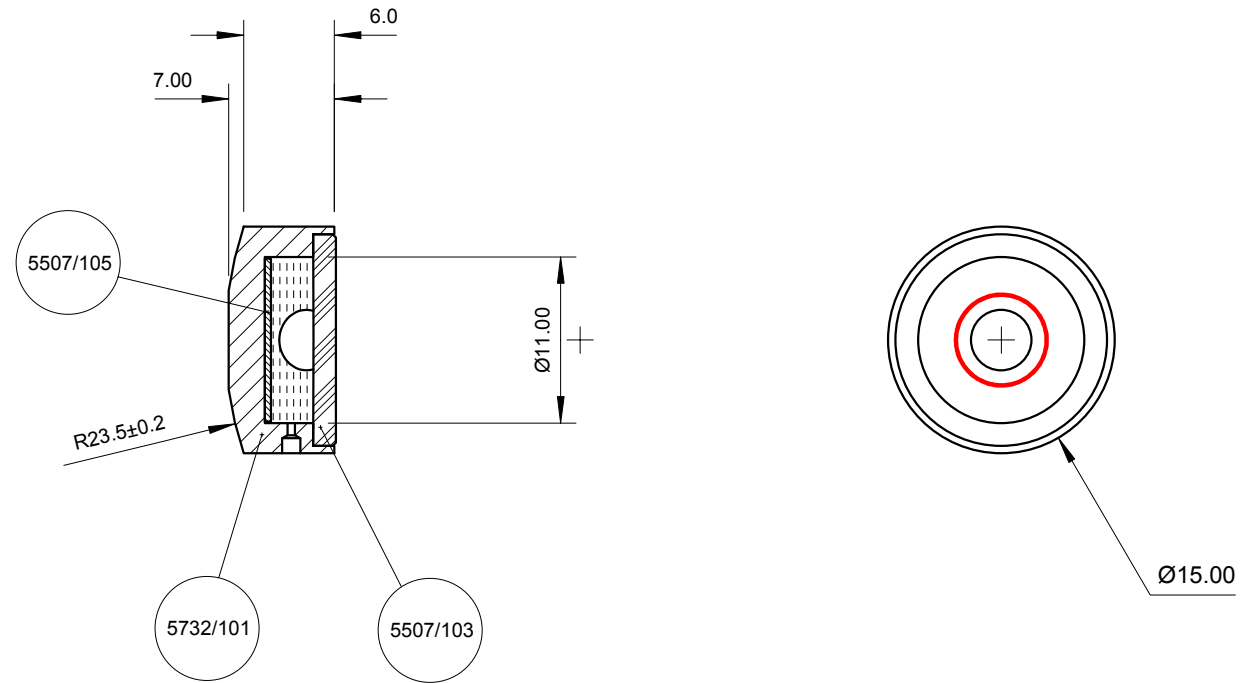

FINISH Clear Anodise	TOLERANCES UNLESS STATED OTHERWISE mm UNITS	<b>XX.</b> +/- 1.0 <b>XX.X</b> +/- 0.25 <b>XX.XX</b> +/- 0.1	MATERIAL Aluminium 6061-T6	<b>LEVEL DEVELOPMENTS</b> Croydon, Surrey, CRO 2DN
			DRAWN BY M. Jones	