

## Electronic Clinometer

Range:  $\pm 60^\circ$   
Resolution:  $0.001^\circ$   
Choice of Outputs

The Electronic Clinometer is an extremely accurate angle measurement device. This compact and rugged sensor is ideal where space is critical and environmental conditions are serious design concerns.

The heart of the system is a patented, capacitance-based sensor with no moving parts. When rotated about its sensitive axis, this unique sensor provides an exceedingly linear variation in capacitance, which is electronically converted into angular data. The sensor and low-power CMOS electronics are encased in a rugged plastic housing ready to install as a system component or as a stand-alone device.

Designed for easy integration, with a choice of analog, ratiometric, digital or serial models, the clinometer produces an output signal corresponding to direction and magnitude of angular displacement.



### Features

- CE certified**
- Just 2" in diameter**
- Rugged plastic housing**
- Extremely accurate**
- Weighs only 2 oz.**

### Applications

- Wheel alignment**
- Construction equipment**
- Antenna positioning**
- Robotics**

### Performance Specifications

---

<b>Total Range</b> .....	$\pm 60^\circ$
<b>Linear Range</b> .....	$\pm 45^\circ$
<b>Threshold</b> .....	$0.001^\circ$
<b>Linearity</b>	
<b>Null to <math>10^\circ</math></b> .....	$\pm 0.1^\circ$
<b>10 to <math>45^\circ</math></b> .....	$\pm 1\%$
<b>45 to <math>60^\circ</math></b> .....	Monotonic
<b>Null Repeatability</b> .....	$0.05^\circ$
<b>Cross Axis Error</b> .....	$< 1\%$ up to $45^\circ$
<b>Time Constant</b> .....	0.3 sec
<b>Freq. Response (-3db)</b> .....	0.5 Hz
<b>RF Susceptibility</b> .....	$< \pm 2^\circ$

---

### Environmental Specifications

---

<b>Temperature Range</b>	
<b>Operating</b> .....	$-30^\circ$ to $65^\circ\text{C}$
<b>Storage</b> .....	$-55^\circ$ to $65^\circ\text{C}$
<b>Temperature Coefficient</b>	
<b>Null</b> .....	$0.008^\circ/\text{C}$
<b>Scale Factor</b> .....	$0.1\%/\text{C}$
<b>EMC</b>	
<b>Emissions</b> .....	EN55022 (CISPR 22) Limit B
<b>Radiated Immunity</b> .....	IEC 801-3 Level 3 10V/m
<b>Burst Transients</b> .....	IEC 801-4 Level 3 (2 kV)
<b>ElectroStatic Discharge</b> .....	IEC 801-2 Level 2 (8 kV air, 6 kV contact)
<b>Conducted RF</b> .....	MIL-STD 461D, CS114, Curve 2
<b>Cable Length</b> .....	18" standard length with flying lead terminator

---

## Electronic Clinometer

Range:  $\pm 60^\circ$   
 Resolution:  $0.001^\circ$   
 Choice of Outputs

### Design Concept

The unique design is based on a common capacitor plate sandwiched between sensor housing halves. The plate has been etched to form two variable capacitors. The assembled sensor is half filled with a dielectric liquid and inert gas. Rotation of the sensor produces a linear change in capacitance resulting in a corresponding output signal.

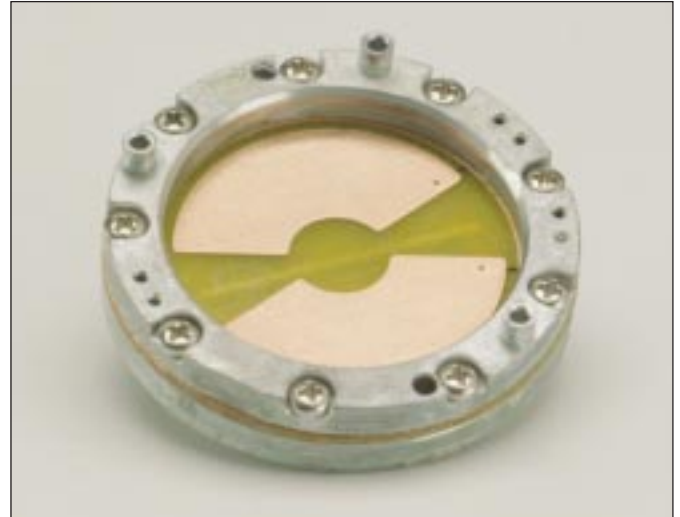

### How to Order

Model Number	Description
	<b>Ratiometric</b>
AS-V-R	Vertical Flange
AS-H-R	Horizontal Flange
	<b>Analog</b>
AS-V-A	Vertical Flange
AS-H-A	Horizontal Flange
	<b>Digital</b>
AS-V-D	Vertical Flange
AS-H-D	Horizontal Flange
	<b>Serial</b>
AS-V-S	Vertical Flange
AS-H-S	Horizontal Flange

### Dimensions in (mm)

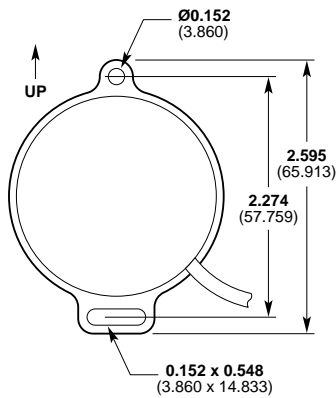

Vertical Flange Mount

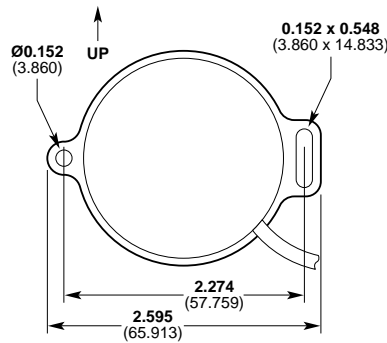

Horizontal Flange Mount

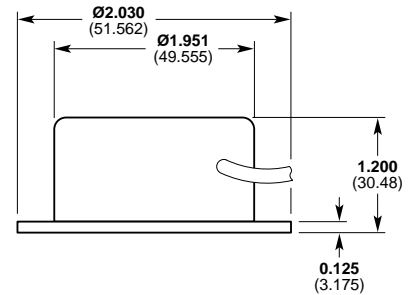

## Electronic Clinometer

### Analog Output

#### Features

- ❑ **Internally regulated**
- ❑ **Bipolar input/output**

The Analog clinometer is a signal conditioned sensor which has been designed for dc voltage, bipolar operation. The clinometer requires a bipolar supply of  $\pm 8$  to  $\pm 15$  VDC and delivers an output of  $\pm 3.6$  VDC. This device is internally regulated for various applications. The output scale is fixed at a nominal 60mV per degree not dependent on the supply voltage. The Analog clinometer has full EMI and ESD suppression circuitry on every line.

#### Analog I/O Block Diagram

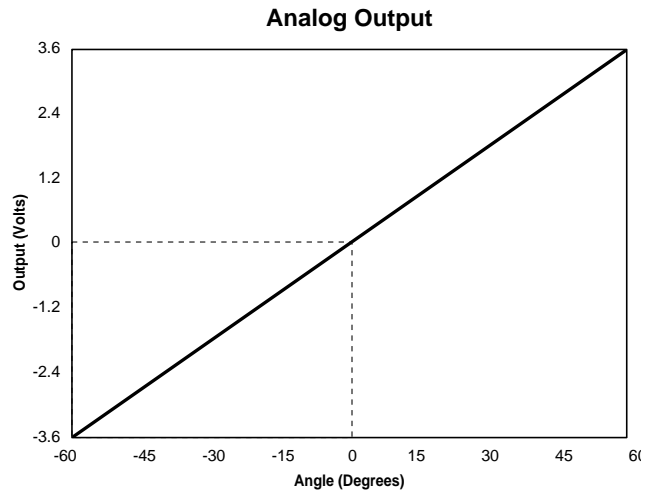
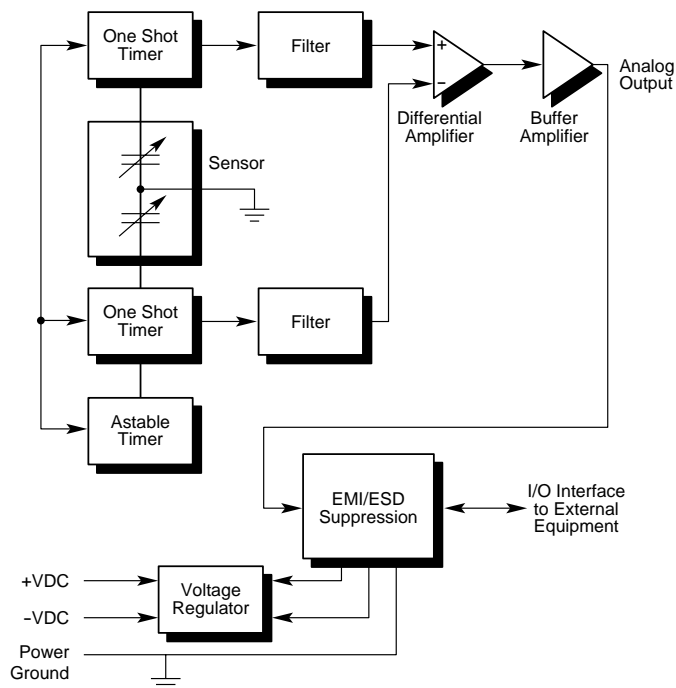

#### Analog Electrical Specifications

##### Voltage

##### Voltage Supply

- Nominal** .....  $\pm 12$  VDC
- Range (regulated)** .....  $\pm 8$  to  $\pm 15$  VDC
- Current** ..... 5 mA/supply
- Scale Factor** ..... 60 mV/degree  $\pm 10\%$
- Load Resistance (min.)** .... 10 kOhms
- Level Output (0°)** ..... 0 VDC

#### Electrical Connections

Wire	Source
<b>Black</b> .....	Power ground
<b>Red</b> .....	+8 to +15 VDC
<b>Gray</b> .....	-8 to -15 VDC
<b>Blue</b> .....	Signal output (reference to power ground)