



LSR Inclinometer

Applications

- ▶ Heavy Construction, Grading
- ▶ Ship & Barge Leveling
- ▶ Deviation Surveys
- ▶ Continuous Casting
- ▶ Weapons Platform Leveling



The LSR Series meets the needs of applications with space constraints. The compact, cylindrical shape and the "stacking" feature of the LSR facilitate the use of several inclinometers when multi-axis measurement is required. The LSR offers precise readings with high outputs at lower range frequencies.

LSR Inclinometer Specifications

Performance

Input Range, °:	±1	±3	±14.5	±30	±90
Full Range Output (FRO), VDC ±1% ¹ :	±5.0	±5.0	±5.0	±5.0	±5.0
Nonlinearity, % FRO ² , maximum:	0.05	0.05	0.02	0.02	0.05
Scale Factor, volts/g nominal:	286.5	95.5	20.0	10.0	5.0
Scale Factor Temp Sensitivity, PPM/°C, maximum:	400	300	100	60	60
Natural Frequency, Hz, nominal ³ :	1.0	2.0	15.0	20.0	40.0
Bandwidth (-3db), Hz, nominal:	1.0	2.0	15.0	20.0	40.0
Input-Axis Misalignment, °, maximum:	0.1	0.15	0.25	0.5	1.0
Output at 0° Tilt, volts, maximum:	0.1	0.04	0.02	0.02	0.02
0° Output Temp Sensitivity, volts/°C, maximum:	0.005	0.003	0.001	0.0005	0.0003
Resolution and Threshold:	1µradian				

Electrical

Input Voltage, VDC ⁴ :	±12 to ±18				
Input Current, mA, nominal:	±15				
Output Impedance, ohms, nominal:	15k	5k	16k	8k	4k
Noise, Vrms, maximum:	0.002				

Environmental

Operating Temp Range:	-18° C to +71° C				
Survival Temp Range:	-60° C to +90° C				
Vibration:	20 grms				
Shock:	1500g, 0.5 msec, 1/2 sine				
Seal:	MIL-STD 202, Method 112				
Weight:	4.0 oz.				

¹ Full Range is defined "from negative full input angle to positive full input angle."

² Nonlinearity is specified as deviation of output referenced to theoretical sine function value, independent of misalignment.

³ Output Phase angle = -90°.

⁴ Unit Power connections can be easily adapted for operations from single-ended, floating power supplies of 24 to 36 Volts DC.



LSR Inclinometer

Dimensional Drawing for the LSR Inclinometer (inch/mm)

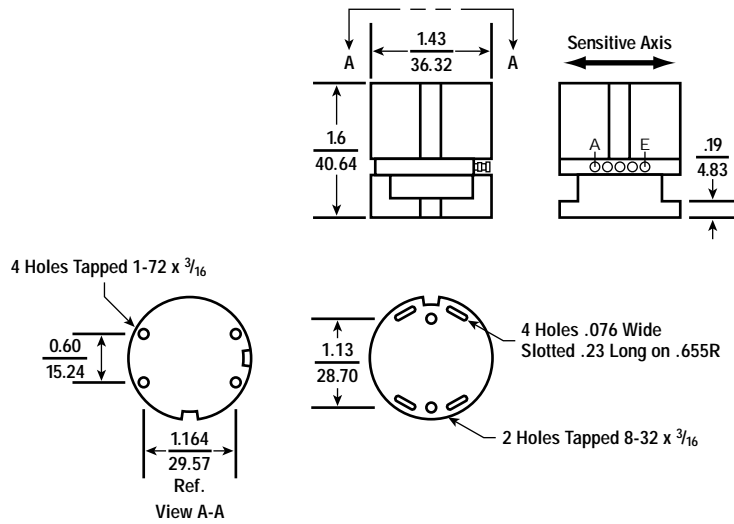

Note: Slots and 1-72 tapped holes permit piggyback mounting with units rotated 90°

Block Diagram for the LSR Inclinometer

