

Used On S40	Scale 1:1	Title S40 Plastic Level Vial	Drawing Number 3420/1	
----------------	--------------	---------------------------------	--------------------------	--

Issue	Amendment	Date
-------	-----------	------

Bubble Size : 11.5mm @ 20°C  
Sensitivity 38"/2mm  
Paralellism of bore to edge : 0.0015mm

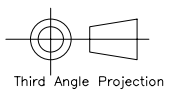
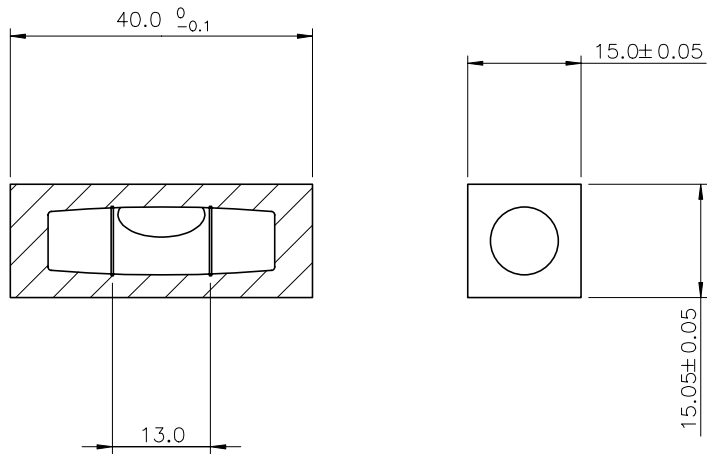

Finish	Tolerances	XX. +/- 1.0	Material	PMMA	Level Developments Ltd
	Unless Stated	XX.X +/- 0.25			
	Otherwise	XX.XX +/- 0.1	Drawn By	JHL	Date
	(mm Units)				23/09/2006
					Croydon, Surrey, CR0 2DN t.+44 (0)20 8684 1400