

Used On 5713/101	Scale 3:1	Title Sensor vial, 20x8mm, sensitivity 5'/2mm	Drawing Number 3754/101
---------------------	--------------	--	----------------------------

Issue	Amendment	Date
-------	-----------	------

Specifications:

- Barrel grinding, R=1375mm
- Polished finish
- Sensitivity 5' ±30" per 2mm bubble movement

Filling:

- Liquid n-Heptane (min 99.9% purity)
- Airbell 8.0±0.3mm @ 20°C

Finish:

- Outside Glass surface to be free from scratches
- No finger prints
- No internal or external dust particles

Packaging:

- Antistatic tape and reel, 500pcs per reel

Inspection:

- 100% automated vision inspection for vial length, bubble size and hysteresis.

Performance:

- Resolution <1 arc second
- Hysteresis <10 arc seconds
- Operating temperature range -20°C to 70°C
- Storage temperature range -40°C to 80°C

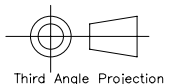
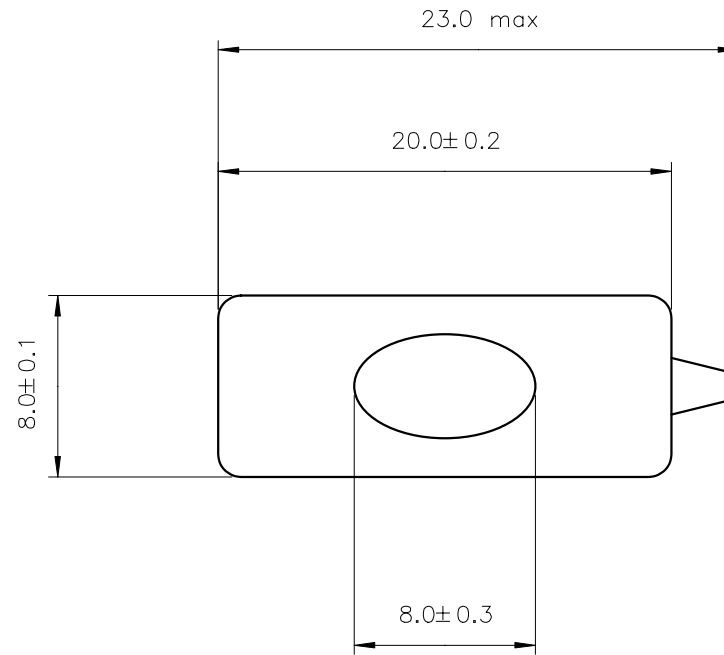

Finish	Tolerances Unless Stated Otherwise (mm units)	XX. ±1.0	Material	Soda glass tube, 8mm diameter		Level Developments Ltd Croydon, Surrey, CR0 2DN t.+44 (0)20 8684 1400
		XX.X ±0.25	Drawn By	JHL	Date	
		XX.XX ±0.1				