

Used On 5794/101	Scale 3:1	Title Sensor vial, 24 x 8mm, sens 4 1/2mm	Drawing Number 3755/101
---------------------	--------------	--	----------------------------

Issue	Amendment	Date
-------	-----------	------

Specifications:

- Barrel grinding, R=1718mm
- Polished Finish
- Sensitivity 4' ±1' per 2mm bubble movement
- Bubble parallelism ±0.5mm

Filling :

- Liquid n-Heptane (pure)
- Airbell 12.0±0.25mm @ 20°C

Finish:

- Outside Glass surface to be free from scratches which affect the optical sensing
- No finger prints
- No internal or external dust particles

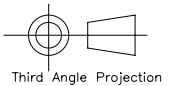
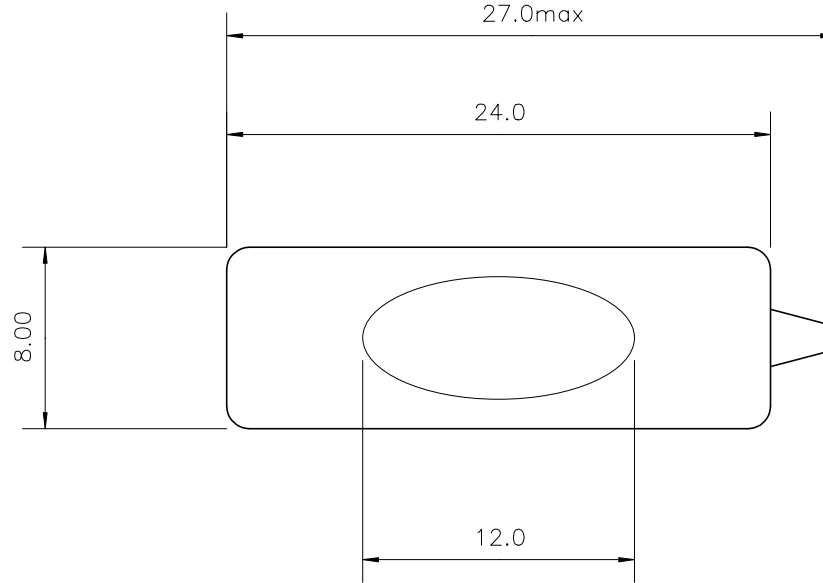

Finish	Tolerances	XX. +/- 1.0	Material	Soda Glass, ø8x0.9mm		Level Developments Ltd Croydon, Surrey, CR0 2DN t.+44 (0)20 8684 1400
	Unless Stated	XX.X +/- 0.25		Drawn By	M. Jones	
	Otherwise	XX.XX +/- 0.1				
	(mm Units)					