

Note:  
 Glass vial, Ø12mm with black ceramic ball Ø11/32"  
 Text height 5mm, width 0.4mm/6.5mm, width 0.6mm  
 Operating temperature range -20 to 60°C  
 Storage temperature range -40 to 60°C  
 Yellow backing  
 Accuracy ±10% of displayed value

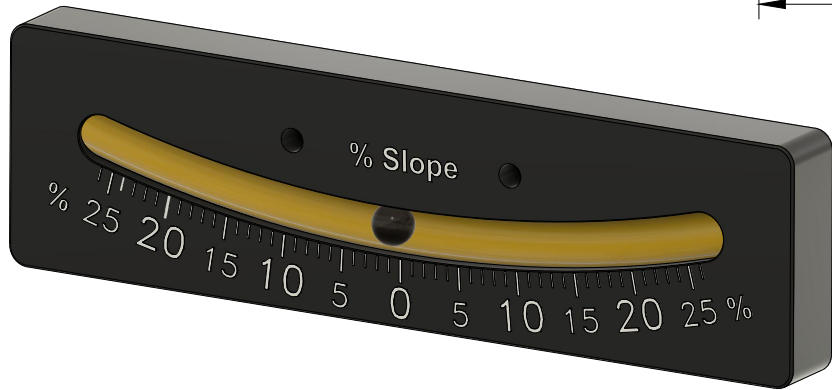
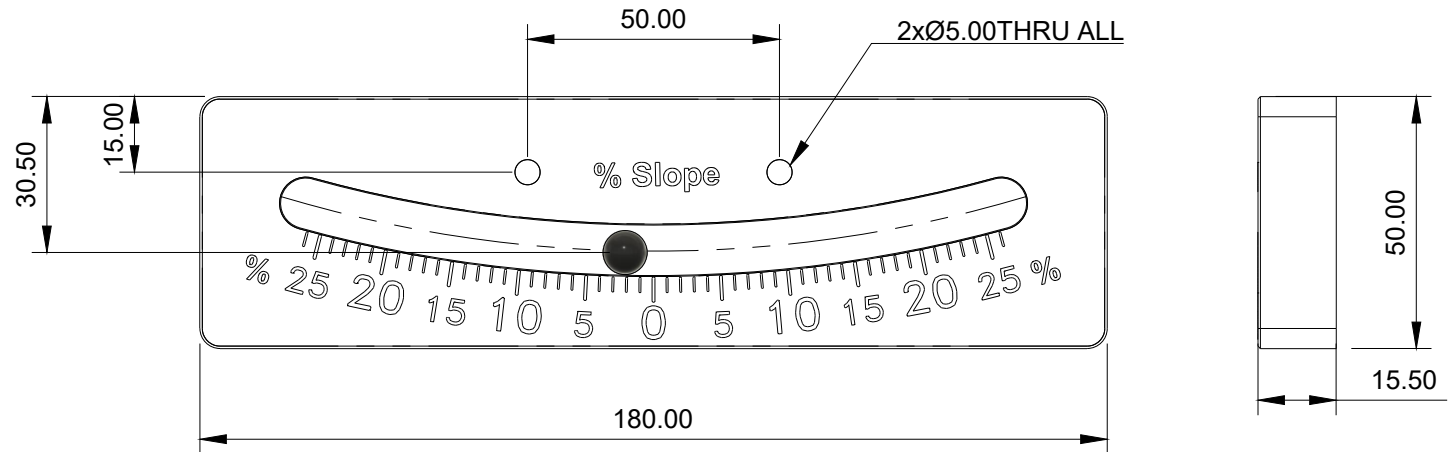

1		Opened for production	11/10/2023
Issue	ECN	Notes	Date

Unless Otherwise Specified Units: mm Tolerances XX ±1.0 XX.X ±0.25 XX.XX ±0.1	THIRD ANGLE PROJECTION 	FINISH: <b>Black Anodised</b> DEBUR AND BREAK SHARP EDGES
NAME	DATE	MATERIAL:
DRAWN Machine Shop	10/10/2023	<b>Aluminum</b>
CHK'D		
APPV'D		
DO NOT SCALE DRAWING		FO079 - Issue 2

TITLE: <b>Ball Inclinometer with % Slope Readings</b>	
DWG NO: <b>6130-2</b>	<b>A4</b>
Used on:	SCALE: 1:2 SHEET: 1/1