



Description

This sensor incorporates a high performance dual axis 3D MEMS sensor. The analogue output voltage varies from 0.5-4.5V over the range of the sensor and is derived directly from the sensor without any digital conversion, so it gives a very high resolution output. It is packaged in a small, robust, sealed Aluminium housing and is supplied with a 2m screened PUR cable (longer on request). There are three measuring range options, ± 10 °, ± 30 ° or ± 90 °, and two options for supply voltage level, either 5Vdc or 9-30Vdc. These sensors are CE certified, and are manufactured and tested in our UK factory.

Features

- Measuring range : ± 10 °, ± 30 ° or ± 90 ° dual axis
- Sealed to IP67
- Solid state 3D MEMS sensor
- Braided screen 4 core cable, 2m standard length, others on request
- High resolution 0.5-4.5V analogue voltage output directly from sensing element
- Low cost relative to performance
- Small size, 46 x 43.5 x 13.5mm



Typical Applications

- Position feedback for solar tracking systems
- Platform levelling and monitoring
- GPS compensation
- Agricultural and industrial vehicle tilt monitoring
- Telescopic and scissor lift platform monitoring
- Robotics position sensing
- Can be readily customised to suit most applications

Specifications

Parameter	DAS-10-A	DAS-10-R ⁽²⁾	DAS-30-A	DAS-30-R ⁽²⁾	DAS-90-A	DAS-90-R ⁽²⁾	Unit
Supply Voltage	9-30	5 ± 0.2	9-30	5 ± 0.2	9-30	5 ± 0.2	V dc
Operating Current	5	5	5	5	5	5	mA
Output Impedance	100	100	100	100	100	100	Ω
Operating Temperature	-40 to 85	-40 to 85	-40 to 85	-40 to 85	-40 to 85	-40 to 85	°C
Size: Width	46.0	46.0	46.0	46.0	46.0	46.0	mm
Length	43.5	43.5	43.5	43.5	43.5	43.5	mm
Height	13.5	13.5	13.5	13.5	13.5	13.5	mm
Weight inc. cable	90	90	90	90	90	90	g
Measuring range	± 10	± 10	± 30	± 30	± 90	± 90	°
0° Output Level ⁽¹⁾	2.5	2.5	2.5	2.5	2.5	2.5	V dc
Zero Bias Error	1	1	1	1	1	1	°
Non linearity	0.5	0.5	0.5	0.5	0.5	0.5	%
Sensitivity ⁽³⁾ for first 1° for 1g range	201 11.518	201 11.518	70 4	70 4	35 2	35 2	mV / ° V / g
Sensitivity tolerance	1.5	1.5	1.5	1.5	1.5	1.5	%
Long Term Stability ⁽⁴⁾	0.015	0.015	0.015	0.015	0.015	0.015	°
Noise Density	0.0008	0.0008	0.0008	0.0008	0.0008	0.0008	° / $\sqrt{\text{Hz}}$
Resolution (@3Hz BW)	0.001	0.001	0.001	0.001	0.002	0.002	°
Frequency Response	3	3	3	3	3	3	Hz

Notes:

1. For optimum zero point accuracy, mounting angle of the part can be adjusted.
2. Output of the -R versions are ratiometric to the supply voltage.
3. Output is proportional to the Sine of the input, so the sensitivity changes throughout the range - see page 2 for more detail
4. 1 year stability when powered continuous at 23°C



Housing Drawing

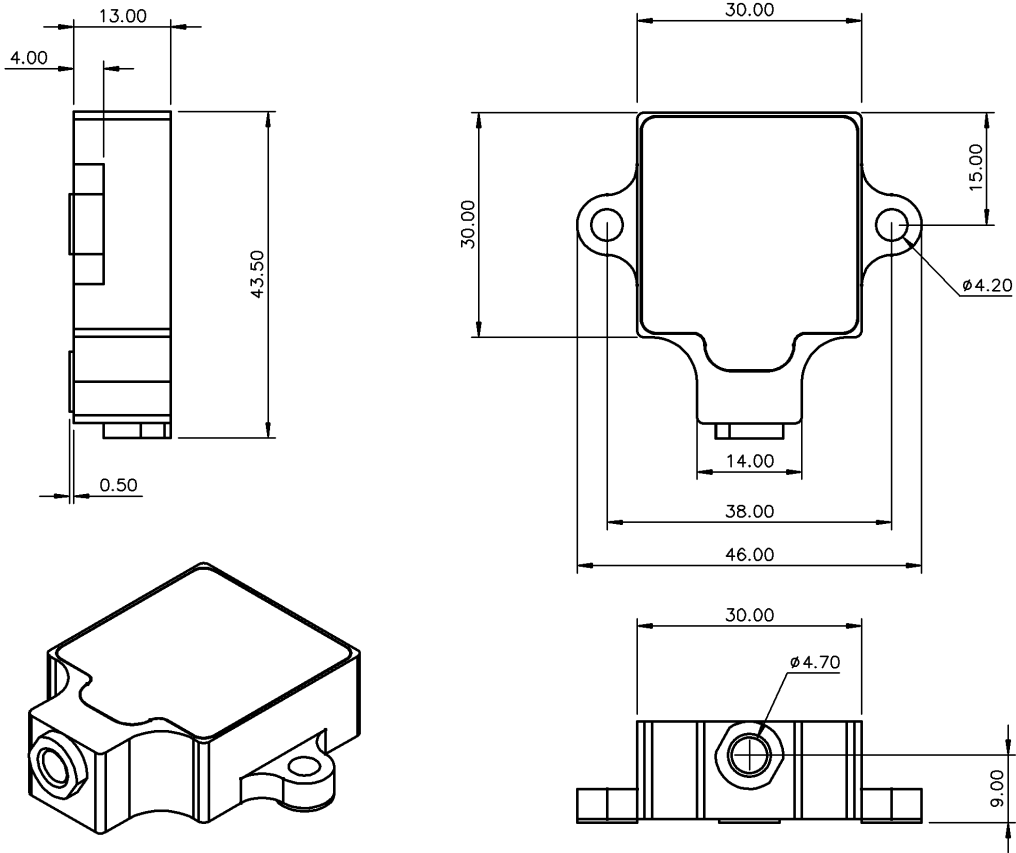

Axis Direction and Mounting Orientation and Wiring Details

Horizontal surface is the zero plane

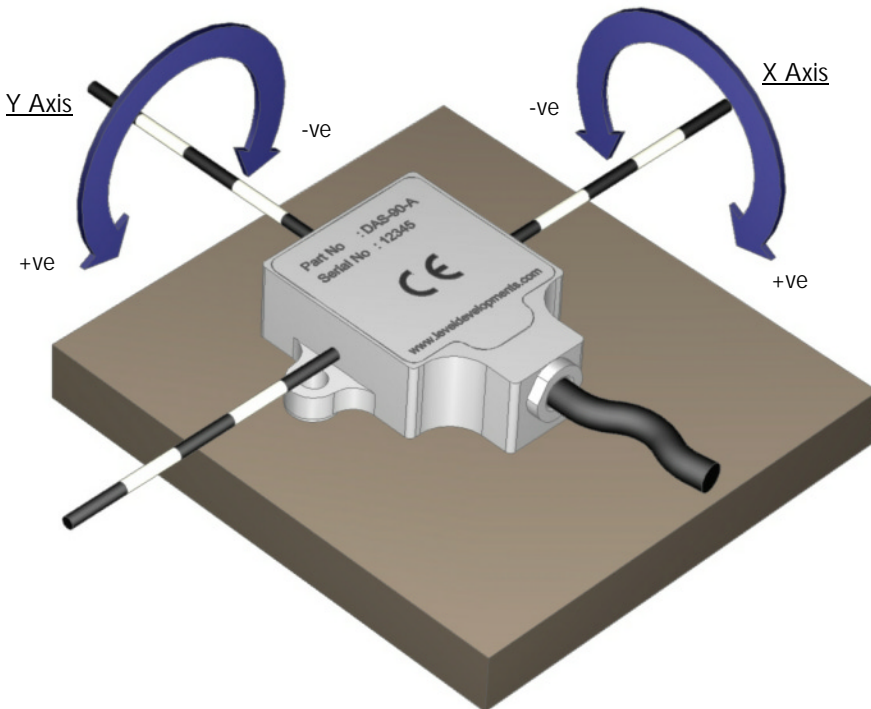

Wire Colour	Function
Red	+Ve Supply
Blue	GND
Yellow	X Axis Output
Green	Y Axis Output



Voltage Output Change With Angle

All inclinometers measure a change in gravitational field to derive angle. As the inclinometer sensor is rotated, the sensing element is subject to gravitational forces which move the proof mass, and this movement is detected and converted to a voltage. In this sensor the output is linear with the change in acceleration (g), which means that the output is a Sine function of the change in angle (°). The graphs below show the output voltage vs. angle.

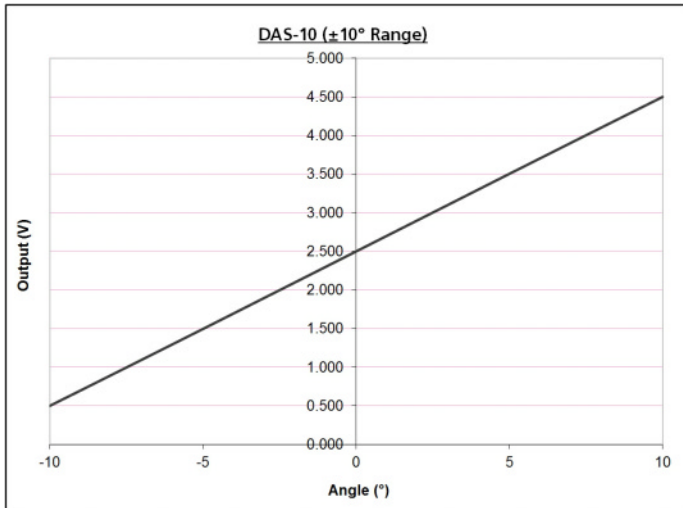

The formula to calculate the angle from the voltage is given by :

$$Angle = \sin^{-1}\left(\frac{V_{out} - V_{offset}}{Sensitivity}\right)$$

Where :

Vout = Measured voltage from the sensor

Voffset = Measured voltage from the sensor when the sensor is at 0° (usually 2.5V)

Sensitivity = Sensitivity of the device [V/g] (see specification table on page 1)

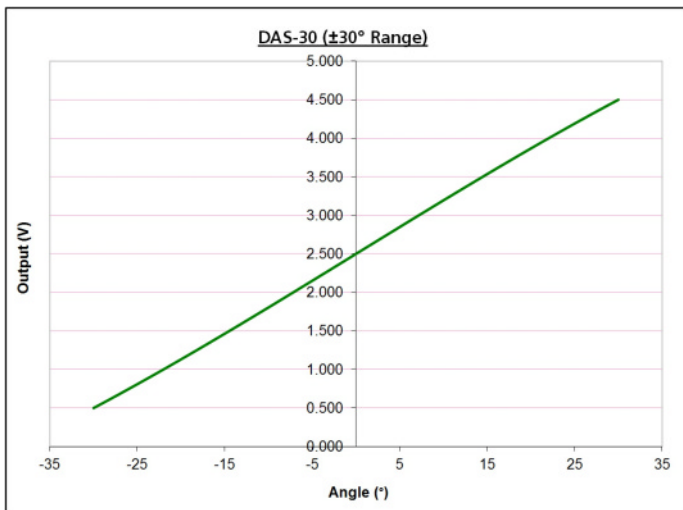

The output is very linear around the zero position, for example at ±10° the sine non linearity would only introduce an error of 0.05°. As the angle approaches 90° the sensitivity of the sensor drops significantly making measurements up to the full 90 degree range much less accurate.

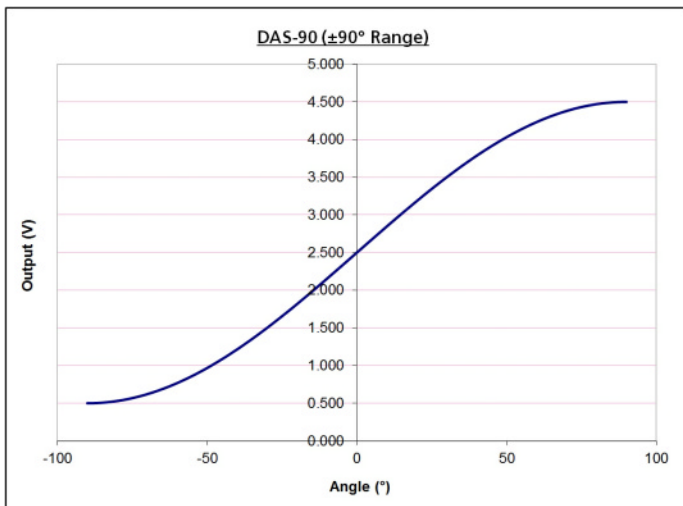



Temperature Performance

One of the largest effects on accuracy for any inclinometer sensor is the effect of temperature. A change in temperature can cause a shift in the zero position (known as zero bias temperature error) as well as affecting the overall sensitivity of the device (known as sensitivity temperature error). The graphs below show the performance of typical and worst case devices for these two errors.

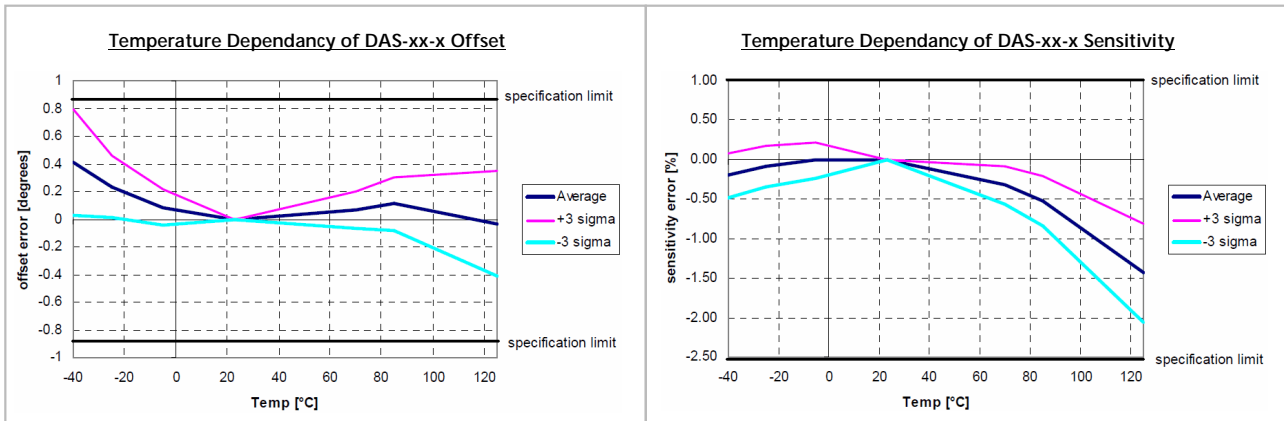

Cable Details

1. Core wires, tin plated copper, 18x0.1mm strands per conductor (26 AWG).
2. 4 conductors, colours red, black, yellow and green. Polypropylene core insulation.
3. Braided screen of tin copper wire with minimum 85% coverage.
4. Black PUR Solar jacket. Flame retardant, reduced smoke generation, zero halogen, excellent for use in water and oil, good for use in acids and fuels, radiation tolerance: 10E6 Gy, UV stable, suitable for continuous outdoor use.

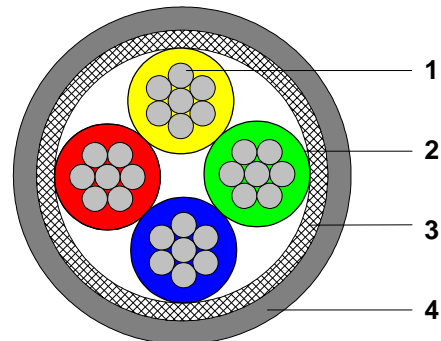

Parameter	Value	Unit	Notes
Approximate Weight	40	g/m	
Operating Temperature	-40 to 85	°C	
Conductor Resistance	100	Ω /Km	Maximum resistance
Insulation Resistance	1500	M Ω /Km	Minimum resistance
Test Voltage	3	KV DC	
Voltage Rating	600	V	
Core Current Rating	2	A	At 40°C air temperature
Individual Core Diameter	1.1	mm	
Overall Diameter	4.5	mm	

Wire Colour	Function
Red	Vin
Blue	Gnd
Yellow	X Axis Output
Green	Y Axis Output